

DRAPER[®]

STORMFORCE

INSTRUCTIONS FOR
**230V Electric
Stapler/Nailer**

Stock No.15636 Part No.STNEKSF

IMPORTANT: PLEASE READ THESE INSTRUCTIONS CAREFULLY TO ENSURE THE SAFE AND EFFECTIVE USE OF THIS PRODUCT.



CE

DRAPER[®]

GENERAL INFORMATION

These instructions accompanying the product are the original instructions. This document is part of the product, keep it for the life of the product passing it on to any subsequent holder of the product. Read all these instructions before assembling, operating or maintaining this product.

This manual has been compiled by Draper Tools describing the purpose for which the product has been designed, and contains all the necessary information to ensure its correct and safe use. By following all the general safety instructions contained in this manual, it will ensure both product and operator safety, together with longer life of the product itself.

All photographs and drawings in this manual are supplied by Draper Tools to help illustrate the operation of the product.

Whilst every effort has been made to ensure the accuracy of information contained in this manual, the Draper Tools policy of continuous improvement determines the right to make modifications without prior warning.

1. TITLE PAGE

1.1 INTRODUCTION:

USER MANUAL FOR:

230V ELECTRIC STAPLER/NAILER

Stock no. 15636.

Part no. STNEKSF.

1.2 REVISIONS:

Date first published March 2016

As our user manuals are continually updated, users should make sure that they use the very latest version.

Downloads are available from: <http://www.drapertools.com/manuals>

DRAPER TOOLS LIMITED

HURSLEY ROAD

CHANDLER'S FORD

EASTLEIGH

HAMPSHIRE

SO53 1YF

UK

WEBSITE: drapertools.com

PRODUCT HELP LINE: +44 (0) 23 8049 4344

GENERAL FAX: +44 (0) 23 8026 0784

1.3 UNDERSTANDING THIS MANUALS SAFETY CONTENT:

WARNING! Information that draws attention to the risk of injury or death.

CAUTION! Information that draws attention to the risk of damage to the product or surroundings.

1.4 COPYRIGHT © NOTICE:

Copyright © Draper Tools Limited.

Permission is granted to reproduce this publication for personal & educational use only.

Commercial copying, redistribution, hiring or lending is prohibited.

No part of this publication may be stored in a retrieval system or transmitted in any other form or means without written permission from Draper Tools Limited.

In all cases this copyright notice must remain intact.

2. CONTENTS

2.1 CONTENTS

<i>Page content</i>	<i>Page</i>
1 TITLE PAGE	
1.1 INTRODUCTION	2
1.2 REVISION HISTORY	2
1.3 UNDERSTANDING THIS MANUAL	2
1.4 COPYRIGHT NOTICE	2
2 CONTENTS	
2.1 CONTENTS	3
3 GUARANTEE	
3.1 GUARANTEE	4
4 INTRODUCTION	
4.1 SCOPE.....	5
4.2 SPECIFICATION	5
4.3 HANDLING & STORAGE	5
5 HEALTH & SAFETY INFORMATION	
5.1 GENERAL POWER TOOL SAFETY WARNINGS	6
5.2 CONNECTION TO THE POWER SUPPLY	7
6 TECHNICAL DESCRIPTION	
6.1 IDENTIFICATION	8
7 UNPACKING & CHECKING	
7.1 PACKAGING.....	9
7.2 WHAT'S IN THE BOX?	9
8 SETTING THE STAPLER/NAILER	
8.1 LOADING STAPLES AND NAILS.....	10
9 BASIC STAPLER/NAILER OPERATIONS	
9.1 ON/OFF SWITCH	11
9.2 FIRING THE STAPLER/NAILER	11
9.3 CHANGING THE POWER LEVEL	11
9.4 UNBLOCKING JAMMED FASTENERS	11
10 MAINTENANCE	
10.1 MAINTENANCE.....	12
11 OPTIONAL ACCESSORIES.....	13
12 EXPLANATION OF SYMBOLS	
12.1 EXPLANATION OF SYMBOLS	14
13 DISPOSAL	
13.1 DISPOSAL	15
DECLARATION OF CONFORMITY	ENCLOSED

3. GUARANTEE

3.1 GUARANTEE

Draper tools have been carefully tested and inspected before shipment and are guaranteed to be free from defective materials and workmanship.

Should the tool develop a fault, please return the complete tool to your nearest distributor or contact Draper Tools Limited, Chandler's Ford, Eastleigh, Hampshire, SO53 1YF. England. Telephone Sales Desk: (023) 8049 4333 or Product Help Line (023) 8049 4344.

A proof of purchase must be provided with the tool.

If upon inspection it is found that the fault occurring is due to defective materials or workmanship, repairs will be carried out free of charge. This guarantee period covering parts/labour is 12 months from the date of purchase except where tools are hired out when the guarantee period is 90 days from the date of purchase. The guarantee is extended to 24 months for parts only. This guarantee does not apply to normal wear and tear, nor does it cover any damage caused by misuse, careless or unsafe handling, alterations, accidents, or repairs attempted or made by any personnel other than the authorised Draper warranty repair agent.

Note: If the tool is found not to be within the terms of warranty, repairs and carriage charges will be quoted and made accordingly.

This guarantee applies in lieu of any other guarantee expressed or implied and variations of its terms are not authorised.

Your Draper guarantee is not effective unless you can produce upon request a dated receipt or invoice to verify your proof of purchase within the guarantee period.

Please note that this guarantee is an additional benefit and does not affect your statutory rights.

Draper Tools Limited.

4. INTRODUCTION

4.1 SCOPE

Ideal for upholstery and furnishing applications and also suitable for repairing fence panels or installing hardboard, etc. It is designed for domestic and light commercial use only. Any other application is considered misuse.

4.2 SPECIFICATION

Stock no.	15636
Part no.	STNEKSF
Voltage	230V~50Hz
Maximum operations per minute	20min ⁻¹
Fasteners:	
Staples (maximum No.100pcs)	6-14mm
Nails (maximum No.80pcs)	14-16mm
Weight	1.38kg

4.3 HANDLING & STORAGE

Although this machine is small in size, care must still be taken when handling and lifting. Dropping this machine will have an effect on the accuracy and may also result in personal injury. This machine is not a toy and must be respected.

The environment will have a negative result on its operation if you are not careful. If the air is damp, components will rust. If the machine is unprotected from dust and debris; components will become clogged: And if not cleaned and maintained correctly or regularly the machine will not perform at its best.

5. HEALTH & SAFETY INFORMATION

5.1 GENERAL POWER TOOL SAFETY WARNINGS

WARNING: Read all safety warnings and all instructions. Failure to follow the warnings and instructions may result in electric shock, fire and/or serious injury.

Save all warnings and instructions for future reference.

The term "power tool" in the warnings refers to your mains operated (corded) power tool or battery-operated (cordless) power tool.

1) Work area safety

- a) **Keep work area clean and well lit.** Cluttered or dark areas invite accidents.
- b) **Do not operate power tools in explosive atmospheres, such as in the presence of flammable liquids, gases or dust.** Power tools create sparks which may ignite the dust or fumes.
- c) **Keep children and bystanders away while operating a power tool.** Distractions can cause you to lose control.

2) Electrical safety

- a) **Power tool plugs must match the outlet. Never modify the plug in any way. Do not use any adapter plugs with earthed (grounded) power tools.** Unmodified plugs and matching outlets will reduce risk of electric shock.
- b) **Avoid body contact with earthed or grounded surfaces such as pipes, radiators, ranges and refrigerators.** There is an increased risk of electric shock if your body is earthed or grounded.
- c) **Do not expose power tools to rain or wet conditions.** Water entering a power tool will increase the risk of electric shock.
- d) **Do not abuse the cord. Never use the cord for carrying, pulling or unplugging the power tool. Keep cord away from heat, oil, sharp edges or moving parts.** Damaged or entangled cords increase the risk of electric shock.
- e) **When operating a power tool outdoors, use an extension cord suitable for outdoor use.** Use of a cord suitable for outdoor use reduces the risk of electric shock.
- f) **If operating a power tool in a damp location is unavoidable, use a residual current device (RCD) protected supply.** Use of an RCD reduces the risk of electric shock.

3) Personal safety

- a) **Stay alert, watch what you are doing and use common sense when operating a power tool. Do not use a power tool while you are tired or under the influence of drugs, alcohol or medication.** A moment of inattention while operating power tools may result in serious personal injury.
- b) **Use personal protective equipment. Always wear eye protection.** Protective equipment such as dust mask, nonskid safety shoes, hard hat, or hearing protection used for appropriate conditions will reduce personal injuries.
- c) **Prevent unintentional starting. Ensure the switch is in the off position before connecting to power source and/or battery pack, picking up or carrying the tool.** Carrying power tools with your finger on the switch or energising power tools that have the switch on invites accidents.
- d) **Remove any adjusting key or wrench before turning the power tool on.** A wrench or a key left attached to a rotating part of the power tool may result in personal injury.

- e) **Do not overreach. Keep proper footing and balance at all times.** This enables better control of the power tool in unexpected situations.
- f) **Dress properly. Do not wear loose clothing or jewellery. Keep your hair, clothing and gloves away from moving parts.** Loose clothes, jewellery or long hair can be caught in moving parts.
- g) **If devices are provided for the connection of dust extraction and collection facilities, ensure these are connected and properly used.** Use of these devices can reduce dust-related hazards.

4) Power tool use and care

- a) **Do not force the power tool. Use the correct power tool for your application.** The correct power tool will do the job better and safer at the rate for which it was designed.
- b) **Do not use the power tool if the switch does not turn it on and off.** Any power tool that cannot be controlled with the switch is dangerous and must be repaired.
- c) **Disconnect the plug from the power source and/or battery pack from the power tool before making any adjustments, changing accessories, or storing power tools.** Such preventive safety measures reduce the risk of starting the power tool accidentally.
- d) **Store idle power tools out of the reach of children and do not allow persons unfamiliar with the power tool or these instructions to operate the power tool.** Power tools are dangerous in the hands of untrained users.
- e) **Maintain power tools. Check for misalignment or binding of moving parts, breakage of parts and any other condition that may affect the power tool's operation. If damaged, have the power tool repaired before use.** Many accidents are caused by poorly maintained power tools.
- f) **Keep cutting tools sharp and clean.** Properly maintained cutting tools with sharp cutting edges are less likely to bind and are easier to control.
- g) **Use the power tool, accessories and tool bits etc. in accordance with these instructions, taking into account the working conditions and the work to be performed.** Use of the power tool for operations different from those intended could result in a hazardous situation.

5) Service

- a) **Have your power tool serviced by a qualified repair person using only identical replacement parts.** This will ensure that the safety of the power tool is maintained.

5. HEALTH & SAFETY INFORMATION

5.2 CONNECTION TO THE POWER SUPPLY

Make sure the power supply information on the machine's rating plate are compatible with the power supply you intend to connect it to.

This product comes supplied with a UK standard 3 pin plug fitted. It is designed for connection to a domestic power supply rated at 230V AC.

This appliance is Class II† and is designed for connection to a power supply matching that detailed on the rating label and compatible with the plug fitted.

If an extension lead is required, use an approved and compatible lead rated for this appliance. Follow all the instruction supplied with the extension lead.

†Double insulated : This product requires no earth connection as supplementary insulation is applied to the basic insulation to protect against electric shock in the event of failure of the basic insulation.

Apart from replacing the fuse in the plug, no other electrical work is recommended on this stapler/nailer.

6. TECHNICAL DESCRIPTION

6.1 IDENTIFICATION

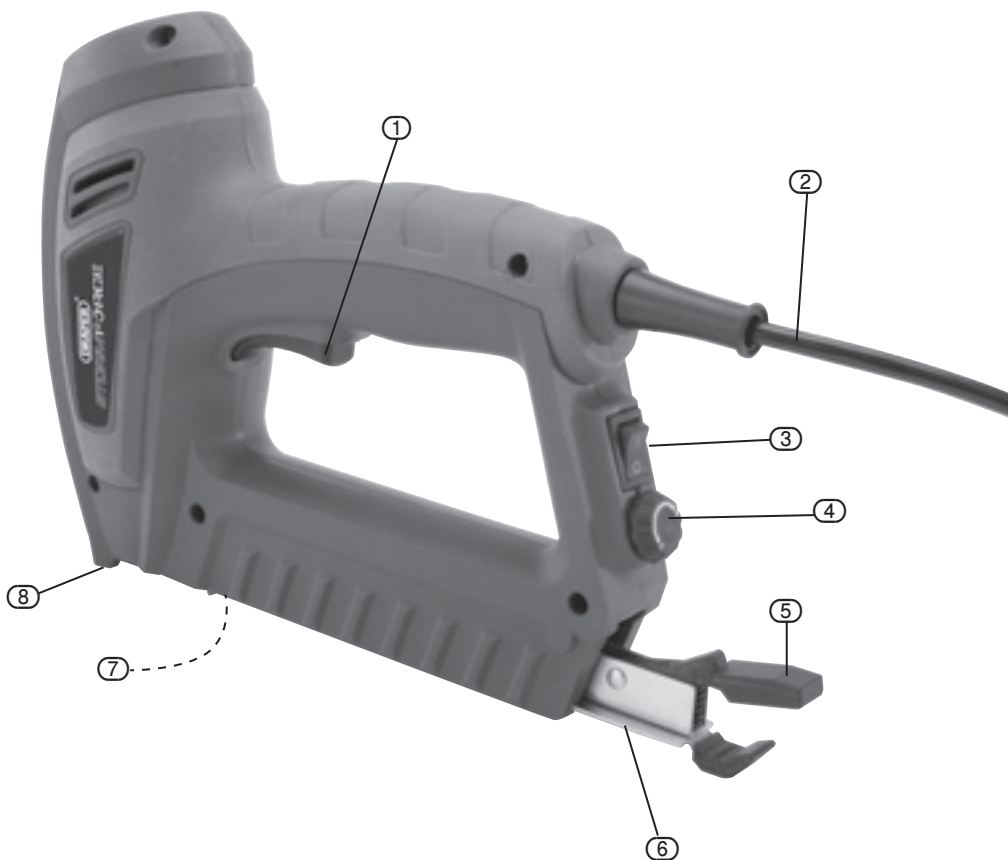

- ① Trigger
- ② Plug & cable
- ③ On/off rocker switch
- ④ Power dial

- ⑤ Magazine lock
- ⑥ Magazine
- ⑦ Chamber
- ⑧ Safety mechanism

7. UNPACKING & CHECKING

7.1 PACKAGING

Carefully remove the product from the packaging and examine it for any sign of damage that may have happened during shipping. Lay the contents out and check them against the parts shown below. If any part is damaged or missing; please contact the Draper Help Line (the telephone number appears on the Title page) and do not attempt to use the tool.

The packaging material should be retained at least during the guarantee period: in case the machine needs to be returned for repair.

Warning! Some of the packaging materials used may be harmful to children. Do not leave any of these materials in the reach of children.

If any of the packaging is to be thrown away, make sure they are disposed of correctly; according to local regulations.

7.2 WHAT'S IN THE BOX?

As well as the product; there are several parts not fitted or attached to it.

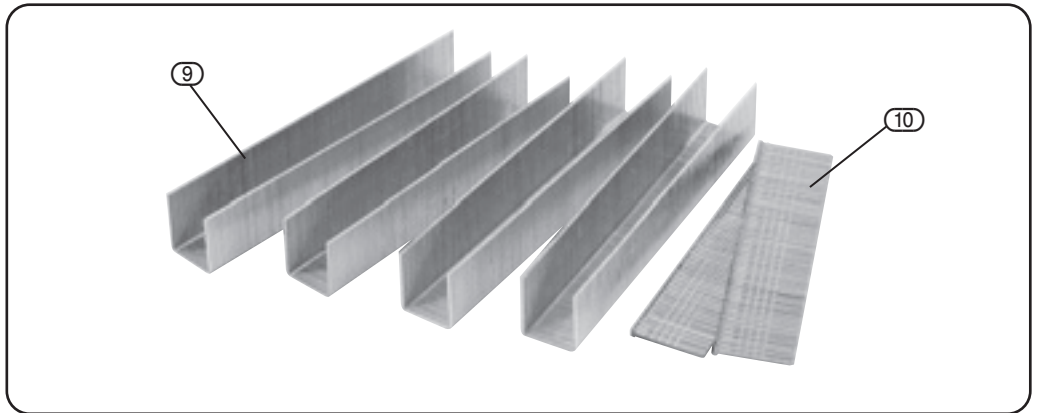

⑨ 14mm crown staples x400

⑩ 15mm brad nails x100

8. SETTING THE STAPLER/NAILER

NOTE: Remove the plug from the socket before carrying out adjustment, servicing or maintenance.

8.1 LOADING STAPLES AND NAILS - FIGS. 1 - 3

At the rear of the magazine is the magazine lock (5). To release it, press the lever down and pull.

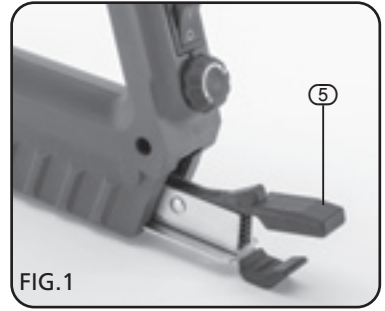

The magazine will accept staples from 6mm up to 14mm.

Load the line of staples into the chamber (7). Push the magazine back and lock in place.

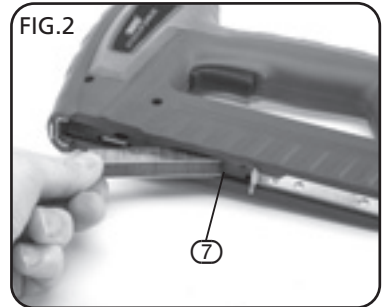

The magazine will accept 'T' nails (Type 'F') SIZES 14-16mm.

Load the line of nails into the slot (7.1) against one side of the chamber.

Do not load on both sides as this will cause the product to malfunction.

Push the magazine back and lock in place.

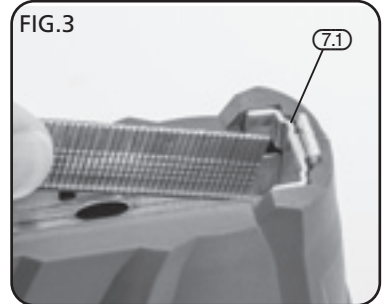

9. BASIC STAPLER/NAILER OPERATIONS

9.1 ON/OFF SWITCH - FIG. 4

To help prevent accidental firing the appliance features an on/off rocker switch (3).

Position the rocker switch to off when not in use.

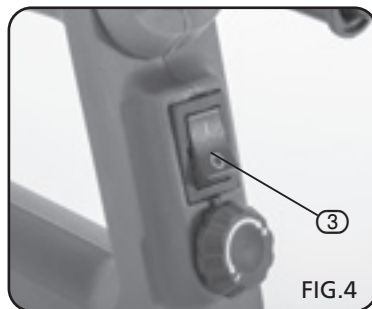

FIG.4

9.2 FIRING THE STAPLER/NAILER - FIG. 5

Push the appliance firmly down on to the surface to activate the safety mechanism (8).

Pull trigger (1) to deploy a fastening.

WARNING: Always wear safety goggles.

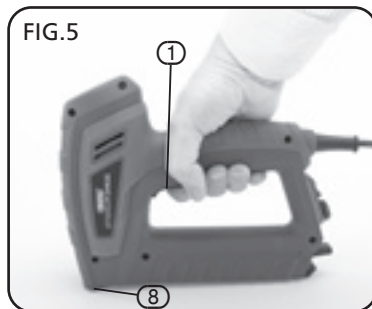

FIG.5

9.3 CHANGING THE POWER LEVEL - FIG. 6

The power level (4) will need to change depending on the material and the size of staples being used.

Note: Try a staple/nail on a piece of spare material to adjust the power level before using on final material.

Example, staple thin fabric onto soft wood with small staples. Turn power down to stop the staples being pushed completely through the fabric deep into the wood.

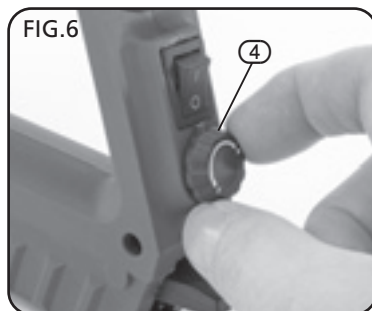

FIG.6

9.4 UNBLOCKING JAMMED FASTENERS - FIG. 7

Note: Remove the plug from the socket before carrying out adjustment, servicing or maintenance.

Should a staple or nail become jammed, it will be necessary to unblock it.

Slide the magazine out, opening the chamber to gain access to the blockage.

A small pair of needle nose pliers may be required to free the blockage.

Reload the magazine and retry.



FIG.7

10. MAINTENANCE

10.1 MAINTENANCE

Regular inspection and cleaning reduces the necessity for maintenance operations and will keep your tools in good working condition.

If the replacement of the supply cord is necessary, this has to be done by the manufacturer or his agent in order to avoid a safety hazard.

11. OPTIONAL ACCESSORIES

STAPLES†

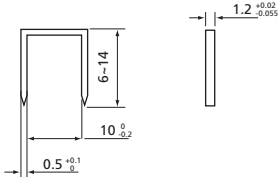

Stock No.	Part No.	Length
13959	1006	6mm
13960	1008	8mm
48951	10010	10mm
48952	10012	12mm
48433	10014	14mm

NAILS†

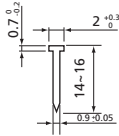

Stock No.	Part No.	Length
59823	AAN15	15mm

† All measurements shown in millimetres.

12. EXPLANATION OF SYMBOLS

12.1 EXPLANATION OF SYMBOLS



WEEE
Do not dispose of Waste Electrical
& Electronic Equipment in with
domestic rubbish



Class II construction
(Double insulated)



Warning!
Read instruction manuals before
operating and servicing this
equipment.



Warning!
Wear goggles.

13. DISPOSAL

13.1 DISPOSAL

- At the end of the machine's working life, or when it can no longer be repaired, ensure that it is disposed of according to national regulations.
- Contact your local authority for details of collection schemes in your area.

In all circumstances:

- Do not dispose of power tools with domestic waste.
- Do not incinerate.
- Do not abandon in the environment.
- Do not dispose of WEEE* as unsorted municipal waste.



* Waste Electrical & Electronic Equipment.

- **DRAPER TOOLS LIMITED,**
Hursley Road, Chandler's Ford,
Eastleigh, Hampshire. SO53 1YF. U.K.
- **Help Line:** (023) 8049 4344
- **Sales Desk:** (023) 8049 4333
- **General Enquiries:** (023) 8026 6355
- **Service/Warranty Repair Agent**
For aftersales servicing or warranty repairs, please
contact the Draper Tools Help Line for details of an
agent in your local area.

YOUR DRAPER STOCKIST

RDKC0416

